

# KN-10

Category II or Category IV Appliance  
(see Installation and Operation Manual for venting information)

## CODE OPTIONS

CSD-1	STANDARD
-------	----------

## INDOOR UNIT

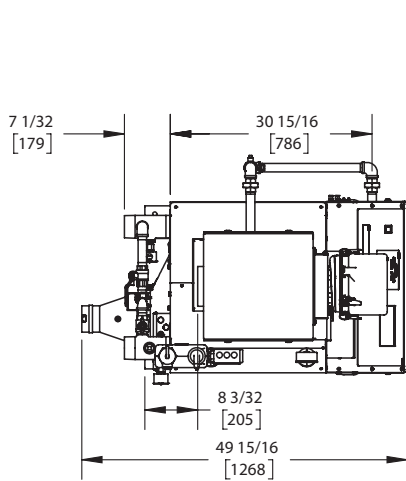

TOP VIEW  
ASUB-4\_L

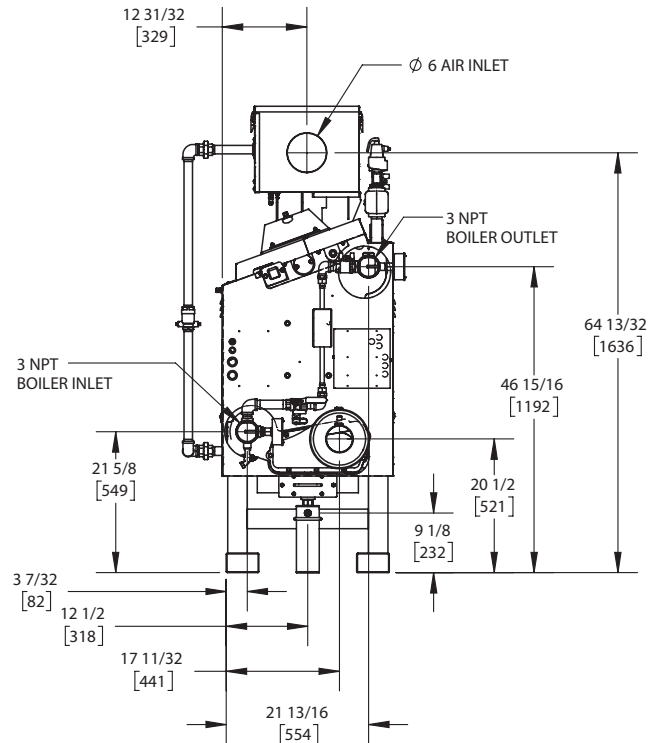

REAR VIEW  
ASUB-4\_L

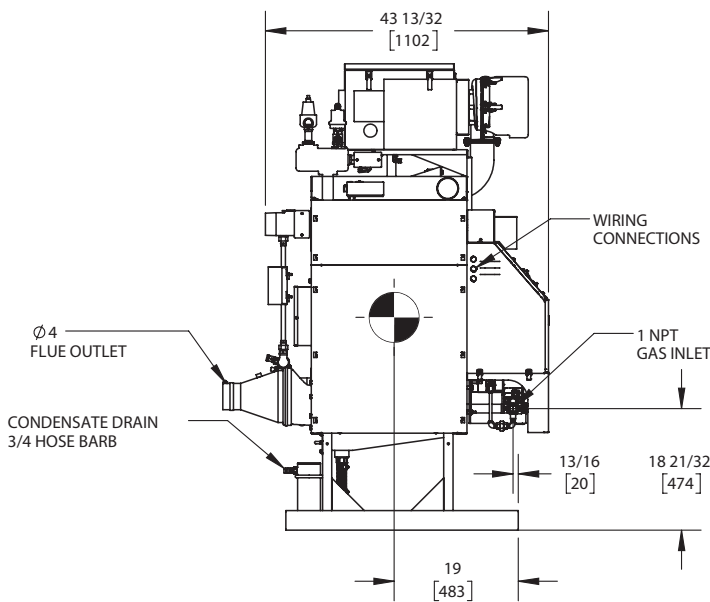

SIDE VIEW  
ASUB-4\_L

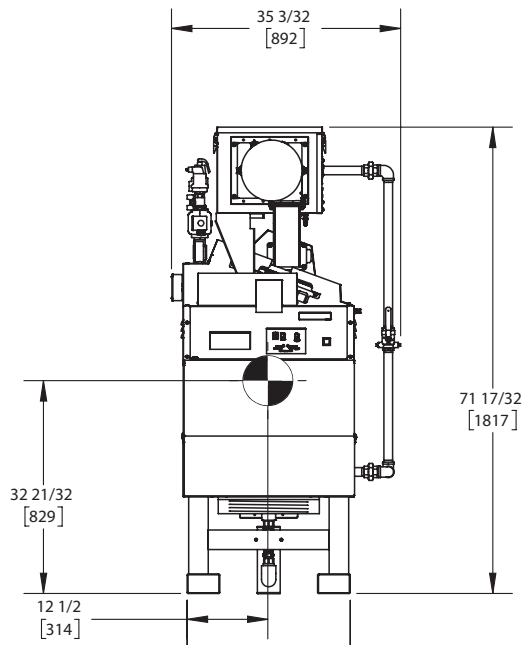

FRONT VIEW  
ASUB-4\_L

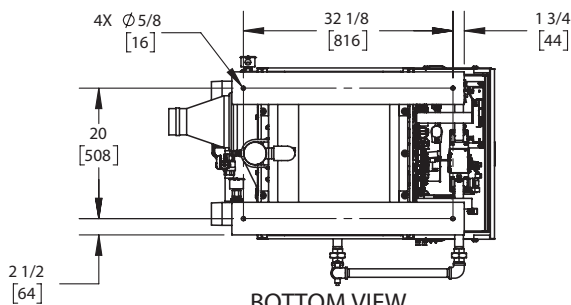

BOTTOM VIEW  
ASUB-4\_L

NOTES:

1. SYMBOL INDICATES CENTER OF GRAVITY.
2. DIMENSIONS ARE NOMINAL AND SUBJECT TO MANUFACTURING VARIATION AND SHOULD NOT BE USED FOR "ROUGHING IN".
3. ALL DIMENSIONS ARE INCHES (mm).



## A.G.A. CERTIFIED RATINGS & CAPACITIES

<b>Fuel Type</b>	Natural/LP Gas	<b>Boiler FLA</b>	15.78 A*
<b>Input BTU/hr.</b>	1000 MBH / 293 KW	<b>Min. Gas Pressure Required</b>	3" W.C.
<b>Output BTU/hr.</b>	900 MBH / 264 KW	<b>Max. Gas Pressure Allowed</b>	14" W.C.
<b>Boiler HP</b>	26.9	<b>Water Volume</b>	11.9 gal.
<b>Electrical Requirements</b>	120VAC/ 60 hz/ 1PH	<b>Operating Weight</b>	1557 lbs. / 707 kg.
<b>SCCR Rating</b>	5kA		

## BOILER TRIM & CONTROLS

<b>Main Gas Valve</b>	Dungs MBC	<b>Air Switch</b>	Huba
<b>Firing Valve</b>	1 1/4" Apollo	<b>Flow Sensor</b>	SIKA
<b>Ignition Control</b>	Honeywell RM7895C	<b>Blocked Flue Switch</b>	Cleveland NS2
<b>Operating Control</b>	HeatNet®	<b>Blower Motor</b>	Ametek
<b>High Limit</b>	Honeywell L4006E	<b>L.W.C.O.</b>	800
<b>Main Ball Valve</b>	1 1/4" Apollo	<b>Relief Valve</b>	30, 50, 75 & 100 PSI
<b>Pilot Cock</b>	1/4" Conbraco	<b>Pilot Regulator</b>	Maxitrol RV12LT

## A.S.M.E.

<b>ASME Sect IV Fire Side Htg Surface</b>	39.89 Sq. Ft. / 3.71 Sq. M.	<b>Design Data</b>	100 PSI & 250°F
<b>ASME Sect IV Water Side Htg Surface</b>	42.65 Sq. Ft. / 3.96 Sq. M.		
<b>CV. GPM (1PSID)</b>	100		

\*Add circulator amps.

## TEMPERATURE RISE / PRESSURE DROP (Based on Full Input)

20°F / 11.1°C				40°F / 22.2°C				60°F / 33.3°C				80°F / 44.4°C				100°F / 55.5°C			
Flow Rate		Pressure Drop		Flow Rate		Pressure Drop		Flow Rate		Pressure Drop		Flow Rate		Pressure Drop		Flow Rate		Pressure Drop	
GPM	L/s	Ft	kPa	GPM	L/s	Ft	kPa	GPM	L/s	Ft	kPa	GPM	L/s	Ft	kPa	GPM	L/s	Ft	kPa
90.0	5.70	1.87	5.60	45.0	2.80	.47	1.40	30.0	1.90	.21	.60	22.5	1.40	.12	.30	18.0	1.10	.07	.20

Flow GPM		Temp. Rise** (°F)		Vent Length (Equiv. Ft.)		Air Inlet Length (Equiv. Ft.)	
Min	Max	Min	Max	Min	Max	Min	Max
18.0	90.0	20	100	6	120***	0	120

\*\*Min/Max delta t reflects boiler operation at full input. For applications requiring operation above/below these parameters please consult factory.

\*\*\*A maximum equivalent length of 80 ft. utilizing 4" vent diameter and 120 ft. utilizing 5" vent diameter.

<b>REP FIRM</b>	_____
<b>SUBMITTED BY</b>	_____
<b>JOB NAME</b>	_____
<b>ARCHITECT</b>	_____
<b>ENGINEER</b>	_____
<b>CONTRACTOR</b>	_____
<b>DATE</b>	_____

# KN-10

**Category II or Category IV Appliance**  
(see Installation and Operation Manual for venting information)



A Division of Mestek, Inc.  
Westfield, MA 01085  
(413) 564-5515

# KN-10

## OUTDOOR UNIT

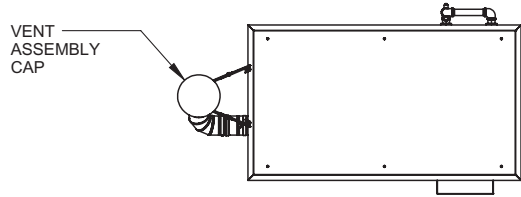

TOP VIEW  
ASUB-33\_E

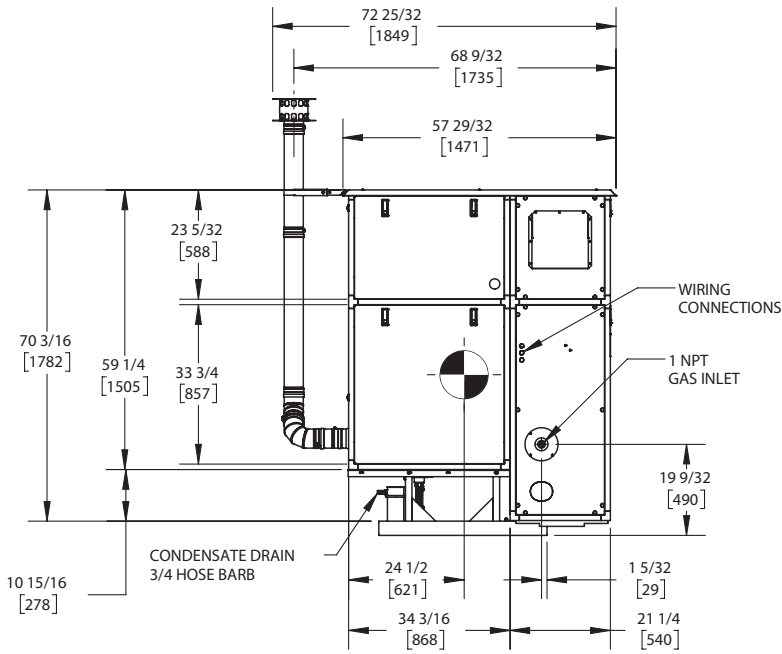

SIDE VIEW  
ASUB-33\_E

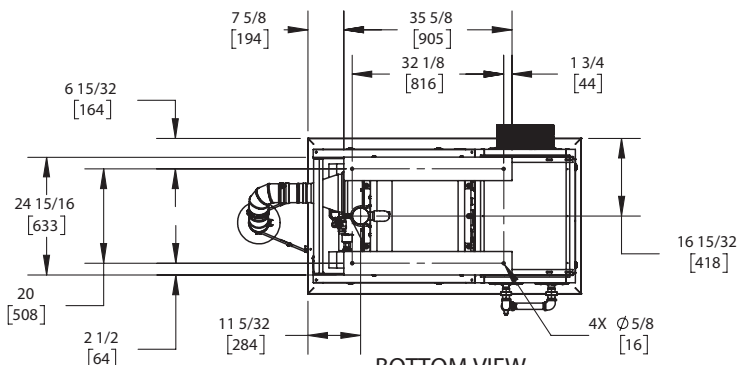

BOTTOM VIEW  
ASUB-33\_E

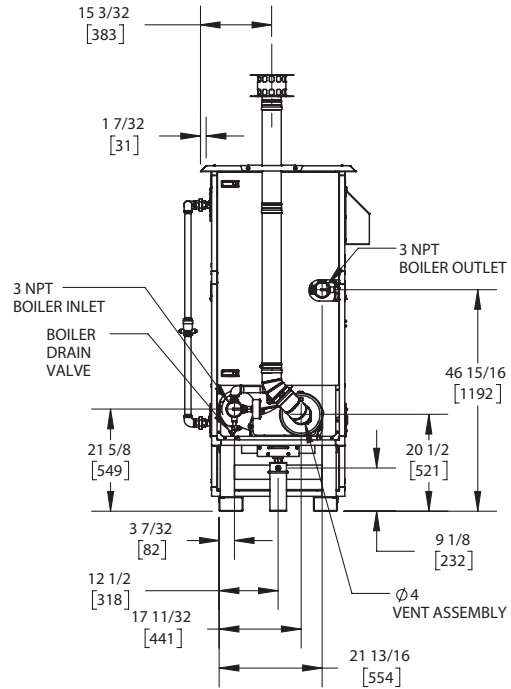

REAR VIEW  
ASUB-33\_E

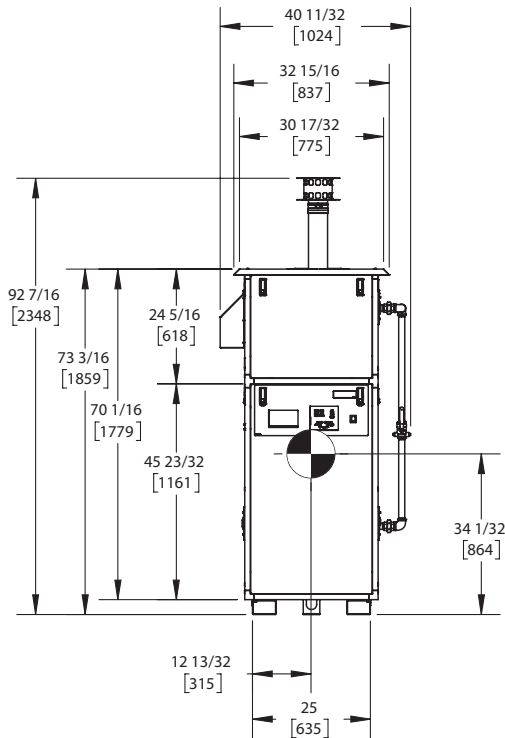

FRONT VIEW  
ASUB-33\_E

NOTES:

1. SYMBOL INDICATES CENTER OF GRAVITY.
2. DIMENSIONS ARE NOMINAL AND SUBJECT TO MANUFACTURING VARIATION AND SHOULD NOT BE USED FOR "ROUGHING IN".
3. ALL DIMENSIONS ARE INCHES [mm].